

DETAIL	DESCRIPTION	PAGE
	Preparation and General Conditions	2
	Shingle installation sequence procedure	3
	General underlayment instructions	3
A	Eave Starter	4
B	Rake Starter (Gable Rollover option)	5
C	Valley Assembly	6
D	End Wall Assembly (Chimney Flashing option)	7
E	Steel Shingle-Shake and Shingle Clip	8
F	Hip and Ridge Assembly (non-vented)	9
G	Hip and Ridge Assembly (vented)	10
	Ridge & Soffit Ventilation Requirements	11
	Roof Vent Flashing	12
	Pipe Vent Flashing	12
	Roof Jack	13
	Shed/Roof (vented)	14
H	Side Wall Installation (Side wall corner, shake to shake detail)	15
J	Starter Strip - Steel #06300 (part shown on page)	15
	Parts List	16

Roofing**Siding****Soffits****Fascia****Gutters****Trims****Accessories**

PREPARATION AND GENERAL CONDITIONS

1. Cartons should be stored in dry place under cover. Carry only one carton at a time and avoid having loose pieces on the roof.
2. Follow all workers compensation and OSHA safety guidelines.
3. Minimum required roof pitch is 4/12.
4. Inspect all roof sheathing and framing to make sure that it is free of warping, in good condition and fastened properly.
5. When re-roofing determine if existing roofing needs to be removed. Before installing new shingle-shakes over existing shingles, remove any mouldings on fascia board, then cut back existing shingles flush with the fascia board at the eave and rake lines.
6. A Class "A" fire rating can be achieved by covering the entire roof area with Georgia-Pacific 1/4" Dens-Deck. The Dens-Deck must be applied directly over the sheathing or existing roof and underneath the new underlayment. Shingle-shakes installed directly over minimum of #30 felt underlayment without 1/4" Dens-Deck will achieve a Class "C" fire rating.
7. The entire roof must be covered with an underlayment prior to installing shingle-shakes. The underlayment should be selected based on climatic weather conditions and must comply with all local building codes. A #30 felt underlayment can be used with double layers at the eaves edge to a point at least 24" inside the exterior wall line, 18" on each side of the centerline along the entire length of the valley and around openings. The underlayments are to be overlapped 2" horizontally and 4" vertically.
8. In weather climates that experience freezing temperatures and high winds it would be advisable to use a polymer modified bitumen ice and water shield in lieu of the bottom layer of doubled underlayment and possibly throughout the entire job. Ice and water shield is recommended for new construction as is following the manufacturer's recommendations. Follow local building codes.
9. Proper attic ventilation is necessary. Using ArrowLine venting hip, ridge and soffit panels are an excellent way to ventilate the attic. See page 3 for details on preparing the roof and page 10 for installing the hip and ridge vents.
10. When walking on roof always wear soft soled shoes or foam rubber soled overshoes and stay close to the top of the shingle-shake just under the butt projection where the shingle-shake is closest to under support. Always avoid walking on four way interlocks of shingle-shakes. Recommended scaffolding methods should always be adhered to.
11. Architects, contractors, and roofing installers must ensure that construction bylaws and building codes are complied with and approved. Before construction begins, building permits may need to be obtained from the local building department. To qualify for protection under the manufacturer's warranty, the application instructions herein must be followed.
12. To qualify for Shingle-Shake UL uplift resistance of 85 psf (approximately 157 mph): use 5 clips per shingle and each clip fastened with a galvanized steel #10 x 1" long hex head zip screw into 15/32 inch minimum plywood substrate.

To qualify for Shingle-Shake UL uplift resistance of 45 psf (approximately 116 mph): use 5 clips per shingle and each clip fastened with a galvanized steel 11 gauge x 1" long steel ring shanked nail into 15/32 inch minimum plywood substrate.

For a detailed UL 580 report for Roofing Systems, Uplift Resistance, see EDCO Products, Inc. File #R20815. UL 2218 Hail Resistance rating of 4 (highest rating).

Shingle installation sequence procedure

For new construction, it is recommended to use ice and water shield instead of #30 felt paper. The ice and water shield seals around screws and nails and is a final water barrier where there are conditions of heavy driving rain and ice dams. Refer to manufacturer's instructions and local building codes.

1. Mount all eave starter trim (detail A - pg. 4).
2. Install 36-inch wide ice and water shield at all eaves and valleys (denoted by dark lines & tint). 24" beyond inside wall.
3. Use 18-inch wide ice and water shield for end walls, vented and non-vented hips / ridges, skylights, rake edge, and any vents through the roof (denoted by tinted area).
4. Cover the rest of the roof with ice and water shield or #30 felt (denoted by white area). Follow local building codes.
5. Install rake starter with 7/8" j-trim (detail B - pg. 5).
6. Install valley flashing (detail C - pg. 6).
7. Install end wall starter with 7/8" j-trim and end wall cap (detail D - pg. 7).
8. Shingle roof completely going from left to right and bottom to top (detail E - pg. 8).
9. Install valley cap (detail C - pg. 6).
10. Use 6-inch wide sub seal over unvented hips and unvented ridges. Mount vented and non-vented hip / ridge cap systems (details F & G - pg. 9 & 10).

General underlayment instructions

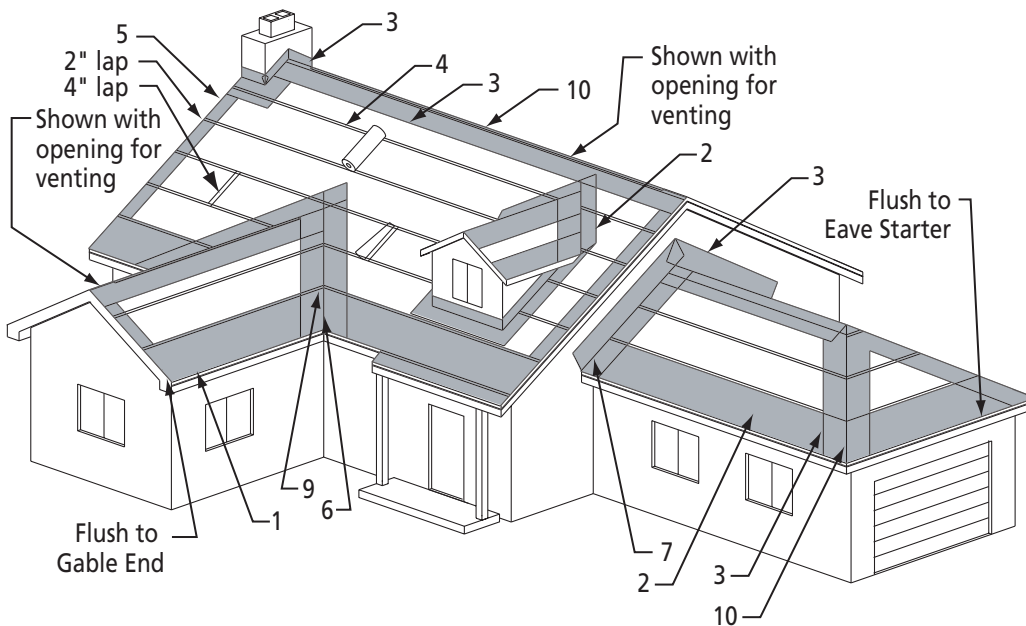

Tools needed

- Hammer
- Chalk line
- Snips
- Caulk gun
- Roofing brackets or jacks
- Utility knife & blades
- Shingle remover
- Korker foam soles
- Knee pads
- Portable brake
- Tape measure
- Hand seamer
- Hand stapler

Installing ice and water shield

Check to see that no nails or staples are protruding from the roof decking before applying ice and water shield. Do not nail any closer than 6" from the rake edge or the bottom of the roof when mounting shingles. Steps 2 & 3 are shown as tinted and Step 4 is shown as white.

- 2a: At the eave starter, overhang the first row of 36" underlayment to be flush to the bottom edge of the eave starter and flush at the gable ends. 24" inside external wall.
- 2b: Install 36" wide underlayment in valley (18" each side with 6" vertical overlap.)
- 3: Use 18" wide underlayment and provide 6" of vertical overlap on hips, ridges, and rake edge.
- 4: Install 36" wide ice and water shield on the entire roof with a minimum of 2" horizontal lap and 4" vertical lap if needed.

Installing #30 felt paper

Check to see that no nails or staples are protruding from the roof decking before applying #30 felt paper. Do not nail any closer than 6" from the rake edge or the bottom of the roof when mounting shingles. Steps 2 & 3 are shown as tinted and Step 4 is shown as white.

- 2a: At the eave starter, overhang the first row of 36" wide underlayment to be flush to the bottom edge of the eave starter and flush at the gable ends.
- 2b: Install 36" wide underlayment in valley (18" each side with 6" vertical overlap).
- 3: Use 18" wide underlayment and provide 6" of vertical overlap on hips and ridges.
- 4: Install 36" wide #30 felt on the entire roof with a minimum of 2" horizontal lap and 4" vertical lap.

REFER TO LOCAL BUILDING CODES.

Eave Starter (Detail A)

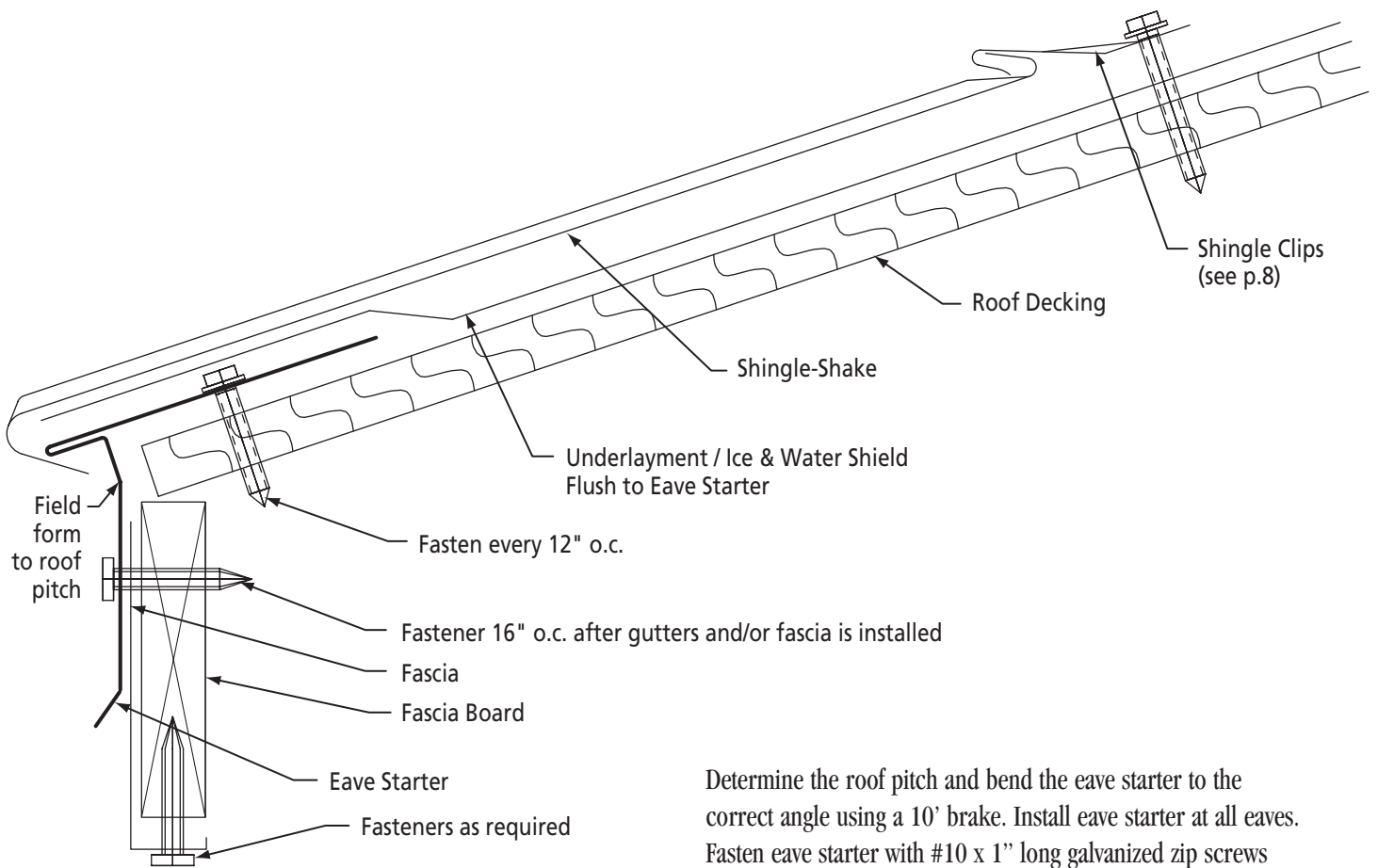

Determine the roof pitch and bend the eave starter to the correct angle using a 10' brake. Install eave starter at all eaves. Fasten eave starter with #10 x 1" long galvanized zip screws 12" o.c. Screw length is to be long enough to penetrate the decking.

Underlayments is to be installed over the eave starter.

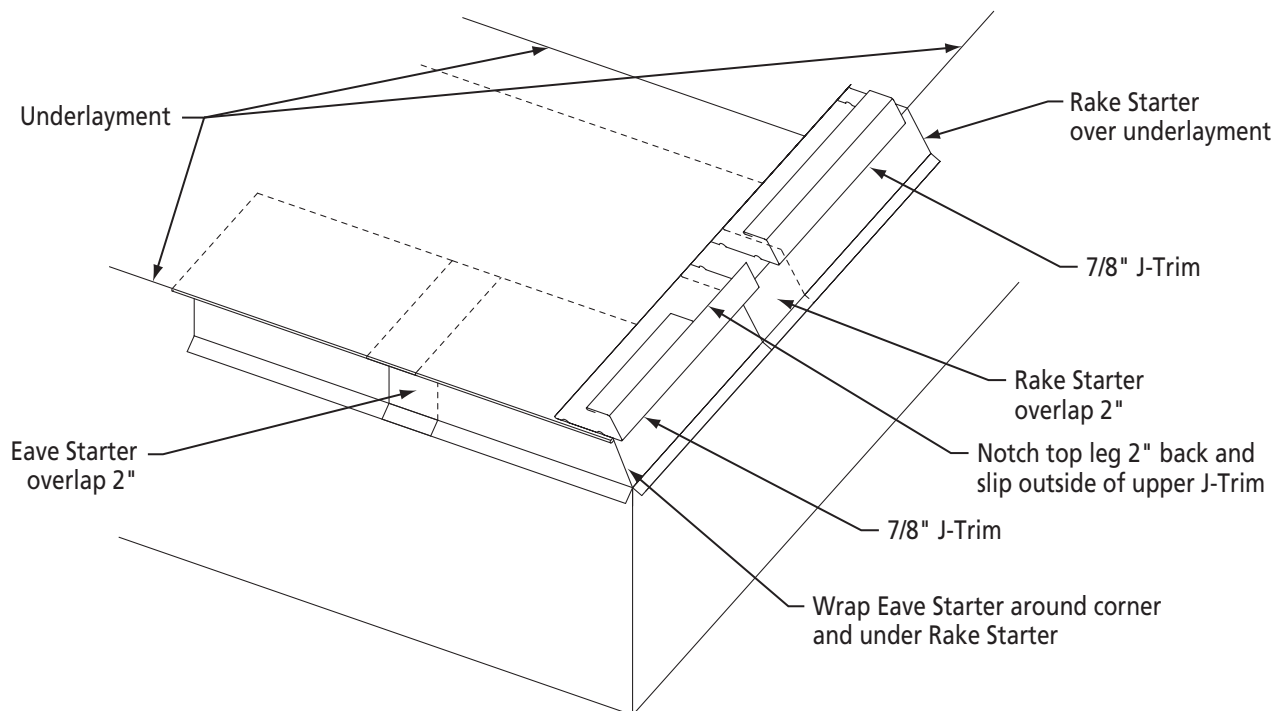

Rake Starter (Detail B)

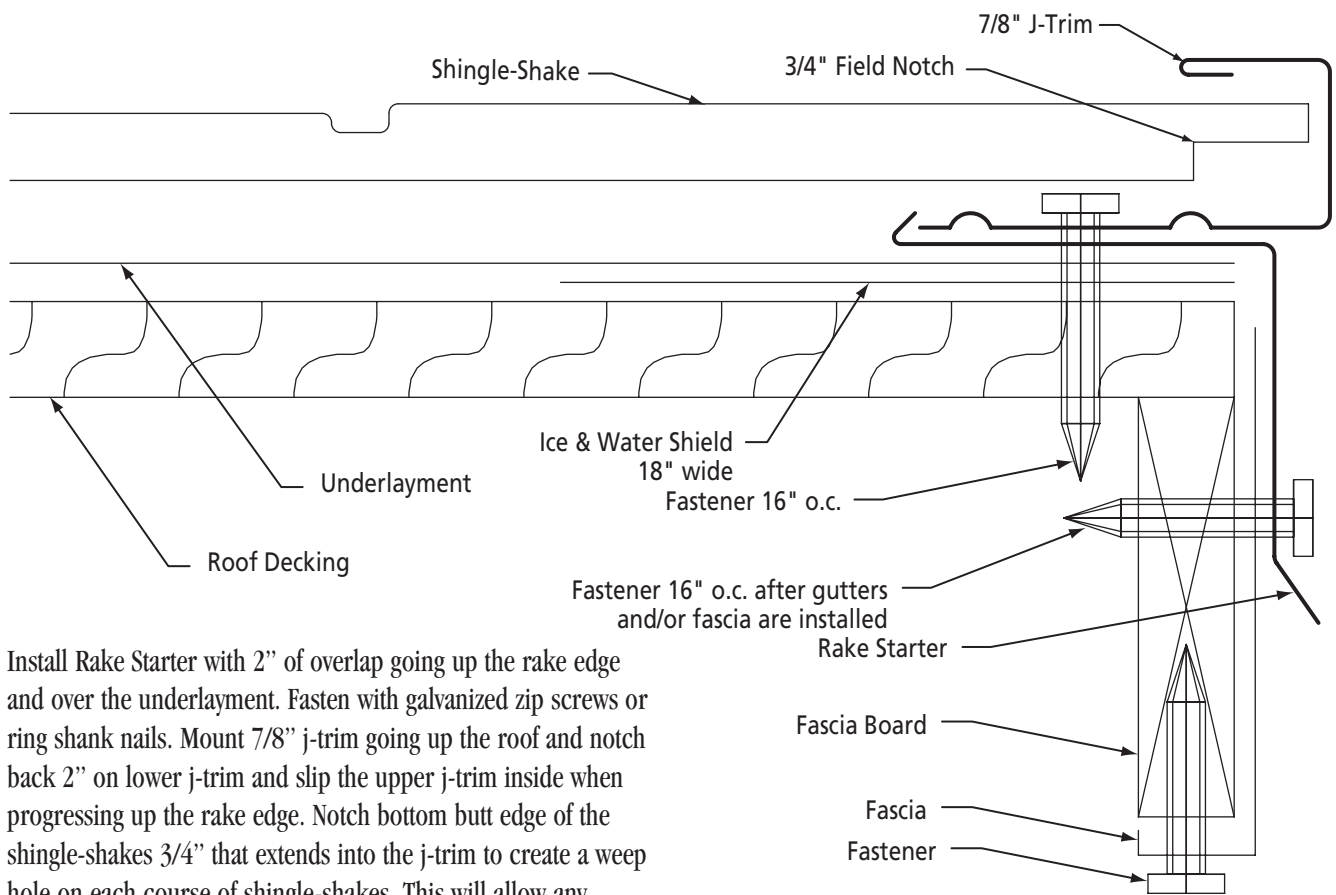

Install Rake Starter with 2" of overlap going up the rake edge and over the underlayment. Fasten with galvanized zip screws or ring shank nails. Mount 7/8" j-trim going up the roof and notch back 2" on lower j-trim and slip the upper j-trim inside when progressing up the rake edge. Notch bottom butt edge of the shingle-shakes 3/4" that extends into the j-trim to create a weep hole on each course of shingle-shakes. This will allow any moisture to seep out at the overhang.

GABLE ROLLOVER

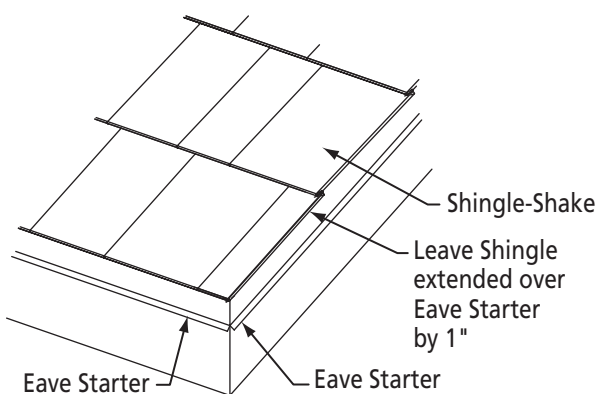
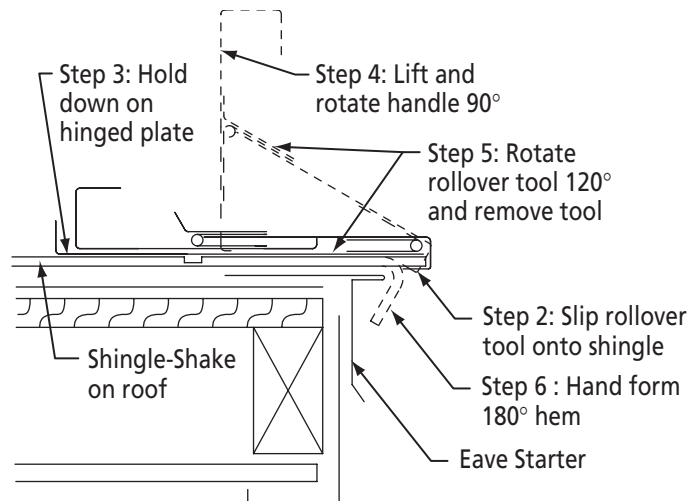
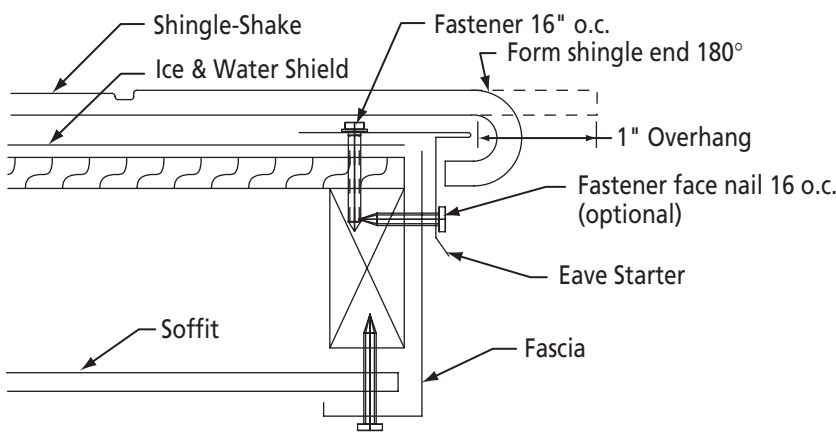

LT Rollover Tool

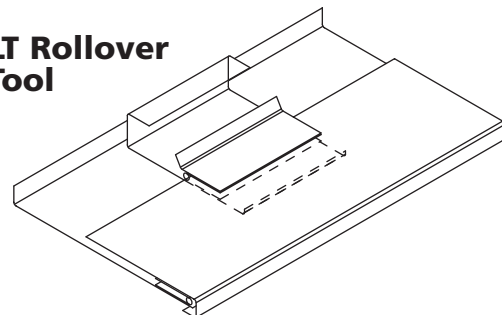

Have the shingle overhang the eave starter by 1" and cut to length. Notch the top leg of the shingle back 1". Then form the shingle overhang around with the LT Shingle Former.

Valley Assembly (Detail C)

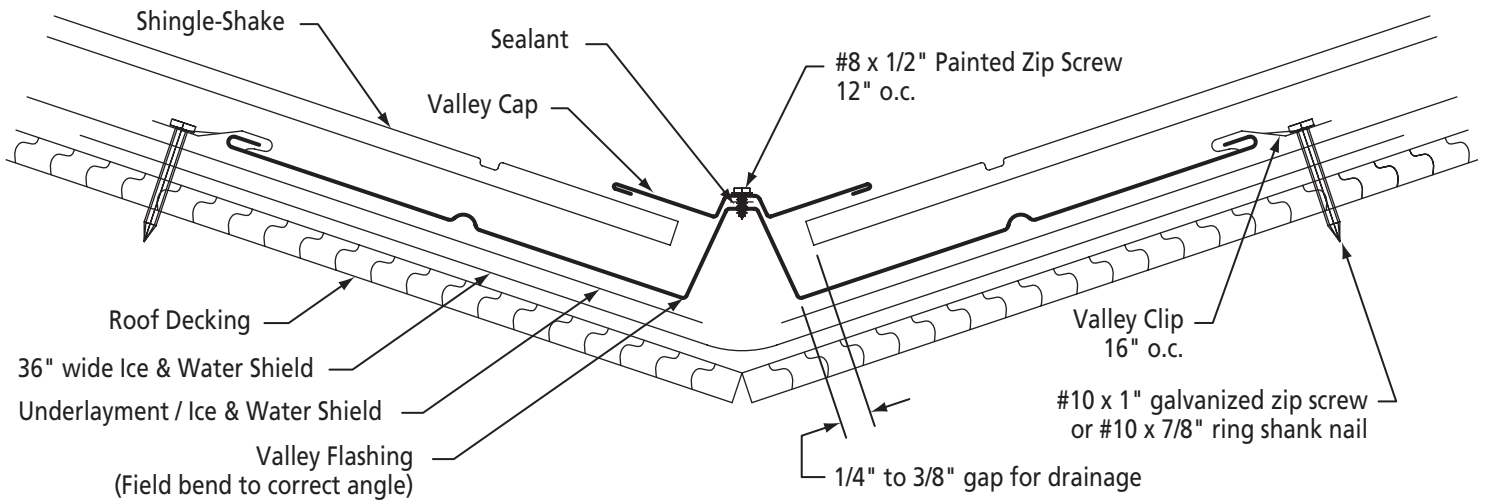

To assure a properly aligned and straight valley installation, it is important to first snap a chalk line on the roof in the center of the valley, running the full length of the valley. Then begin installing the valley flashing starting from the bottom. Trim the bottom of the valley to the correct angle and allow 5/8" to bend around eave starter. Notch hem of top valley and overlap valley 4" and put 2 rows of silicone between overlap. Fasten

valley using valley clips at 16" o.c. Always use sealant when over-lapping accessories.

Use natural curing silicone sealant on center of the flat top on the vee of the valley. Install the valley cap over the valley flashing flat top vee. The valley cap is installed with the lower always 2" over the upper valley cap. Fasten using #8 x 1/2" painted steel zip screws spaced 12" o.c.

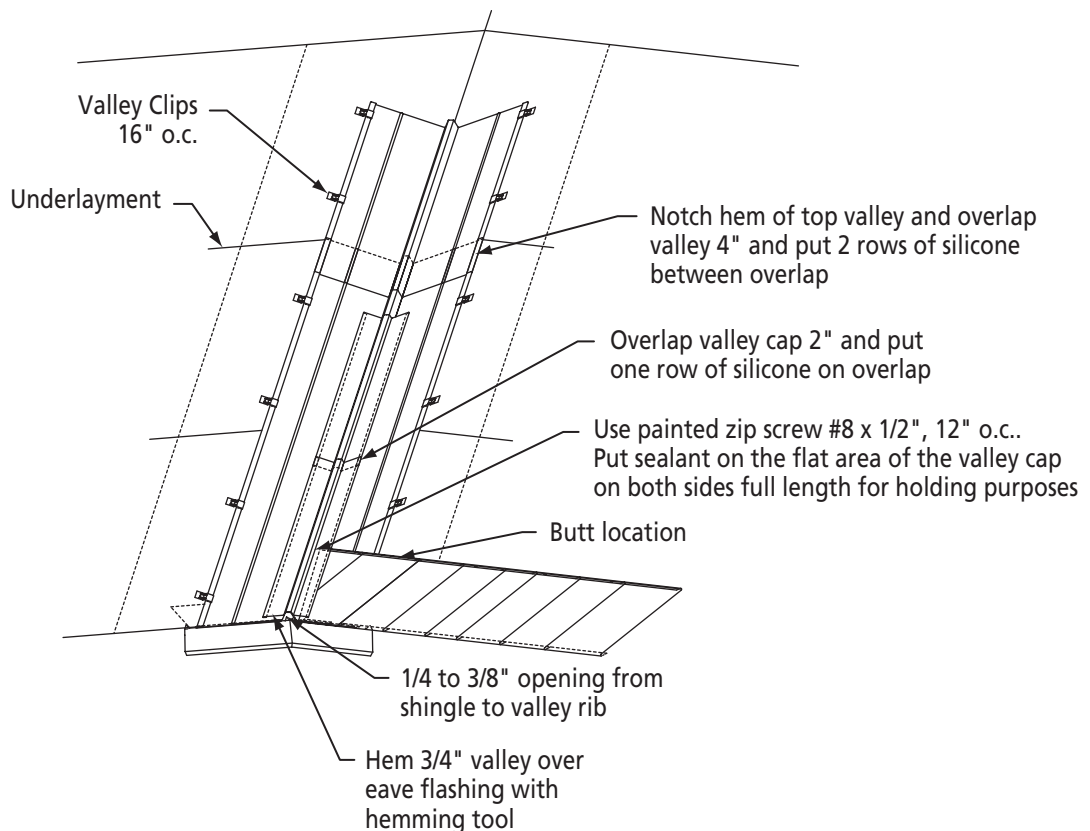

End Wall Assembly (Detail D)

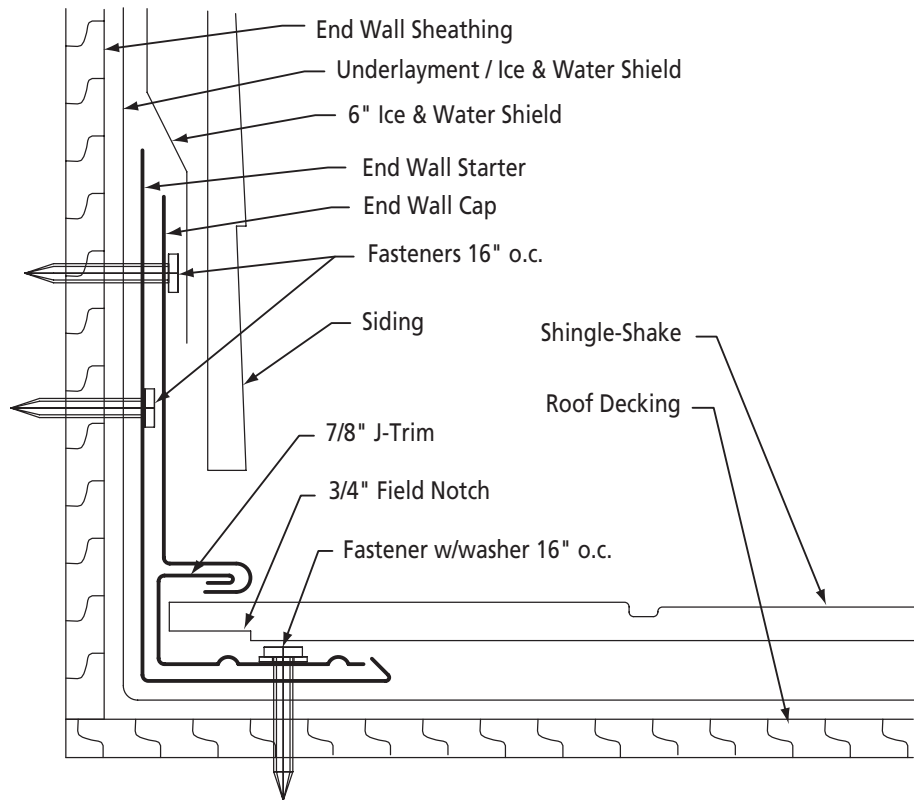

The end wall assembly is designed to be used at the sides of end walls, dormers, chimneys, skylights, etc. Install underlayment of 18" wide ice & water shield as counter flashing. Use matching embossed trim coil when custom top and bottom flashings are required. Always use proper sealants for water tightness.

Begin installing three-piece sidewall assembly (always overlap trims by 4" using sealant) with galvanized ring shank nails. In end wall applications, it is preferable to have the top legs of the end wall starter and end wall

cap flashings go underneath the siding as far as possible. Use 6" ice & water shield seal strip over the end wall starter and cap. When stucco or brick is present on end wall you must cut a kerf approximately 1/2" into the stucco or brick at least 4" above the roof deck. Cut and bend end wall cap flashing to fit into kerf and allow for an edge to apply sealant.

When installing shingle-shakes, notch 3/4" wide weep hole in the bottom butt edge inside the j-trim. Allow the end wall starter to drain any moisture on top of the shingle-shakes.

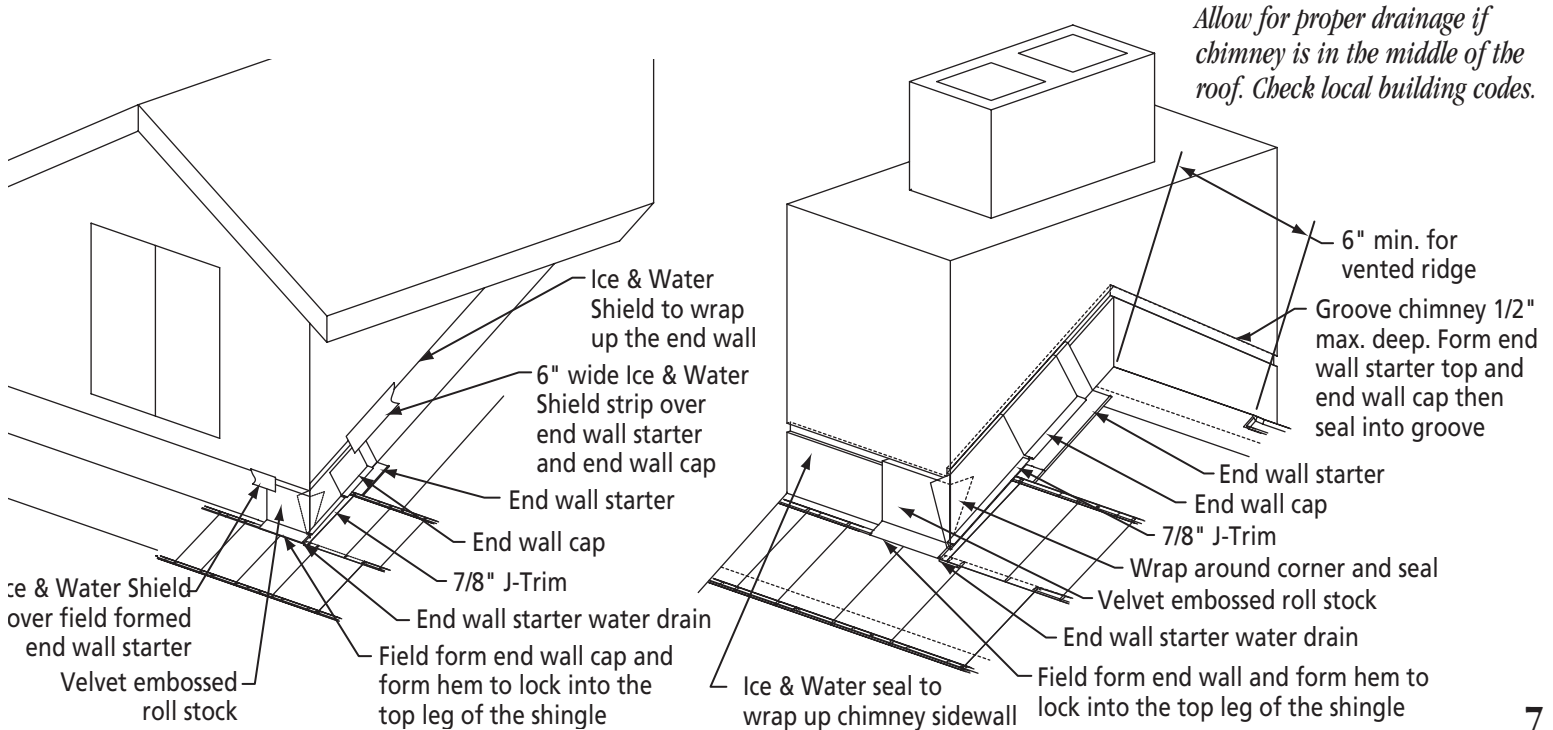

Allow for proper drainage if chimney is in the middle of the roof. Check local building codes.

Shingle-Shake (Detail E)

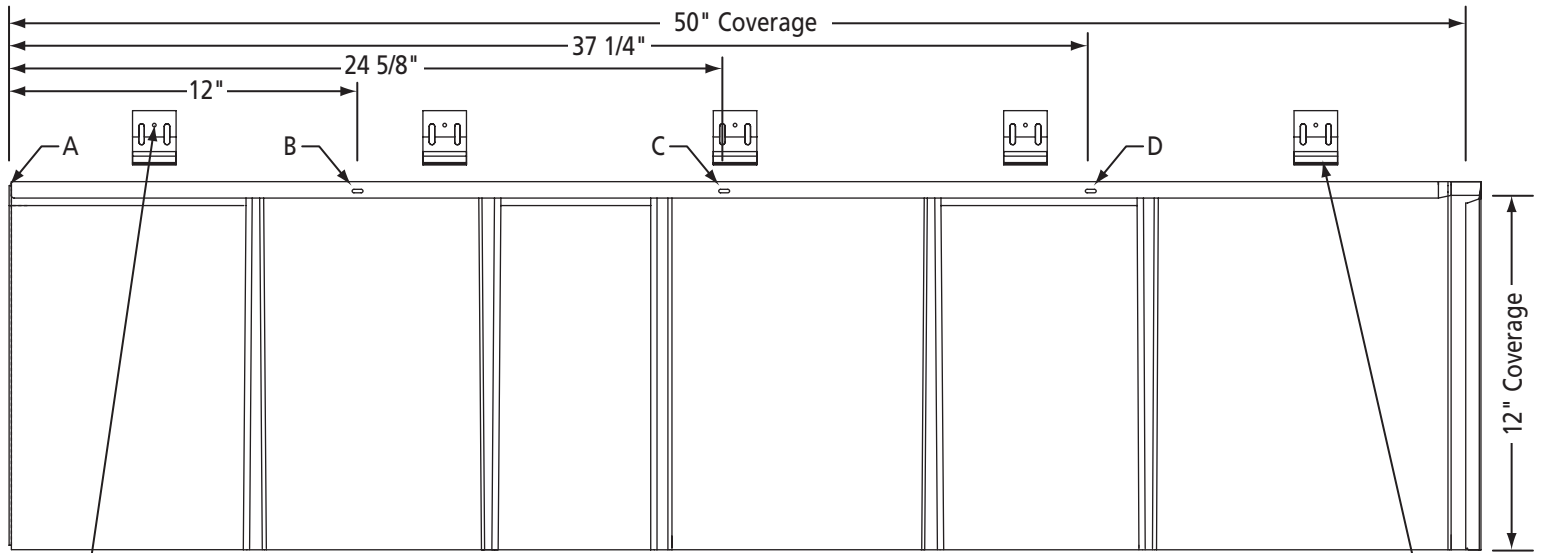

Use #10 x 1" galvanized steel zip screws or #11 x 1" galvanized ring shank nails. Always penetrate a minimum of 1/2" substrate. Note: see page 2 for wind uplift qualifications for screws versus nails and always comply with all local building codes.

Mount shingle clips so that they are in an approximately equally spaced pattern

Shingle-shakes are packaged 12 panels (50 sq. ft.) per carton. Each carton weighs approximately 35 lbs so it can be carried easily to the roof for installation.

After the completion of all prep work and the accessories have been applied, you can begin installing shingle-shakes. Always install shingle-shakes from left to right and attach with 5 shingle clips per shingle-shake. The first and last shingle clip on each course of shingle-shakes should be snipped at the hooking area through the top flange of shingle-shake clip. This procedure will help pin the course in

place and minimize any horizontal shifting of the shingle-shakes (see detail #1 below).

Start the shingle-shake installation at the bottom left hand corner of the roof with a full panel. After installing a number of panels you can start the second course. There are dimples stamped into the top hook of each shingle-shake. As noted above they have been designated "A", "B", "C" and "D". Do not start the second course with a full shingle-shake. In an effort to create a random staggered joint appearance it is recommended to cut the first shingle-shake of the second course at dimple

"D". You may then continue installing shingle-shakes on this course using only full shingle-shakes. You can then begin the third course by cutting the first shingle-shake at dimple "B" and installing it. The fourth course should begin with a shingle-shake cut at dimple "C". The fifth course should be started with a full shingle-shake and you should repeat the above staggering procedure on all subsequent courses.

When installing shingle-shakes at hips or valleys be sure to follow the above cutting procedure to insure the same random staggered pattern.

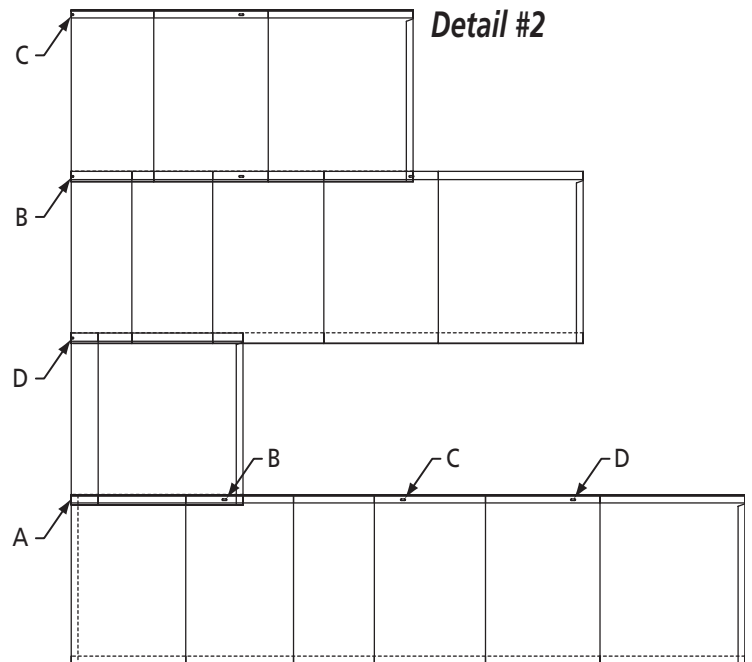
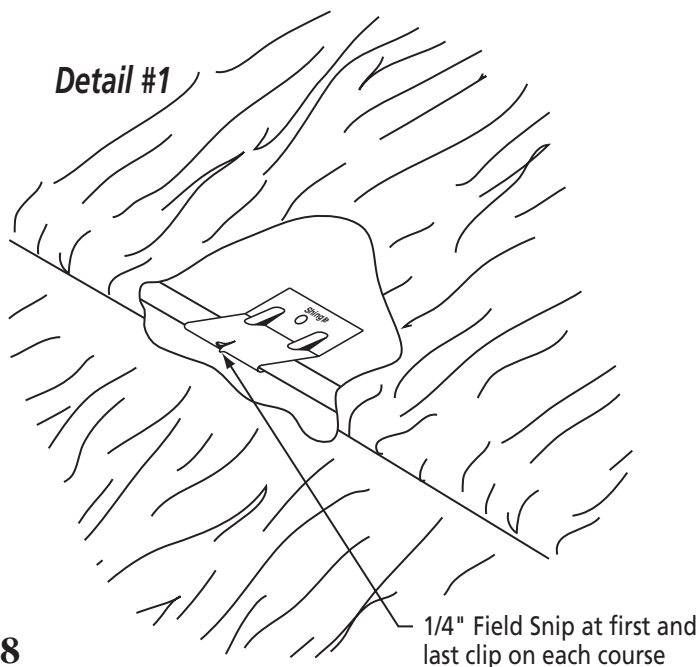

Hip / Ridge Assembly (Detail F)

(non-vented)

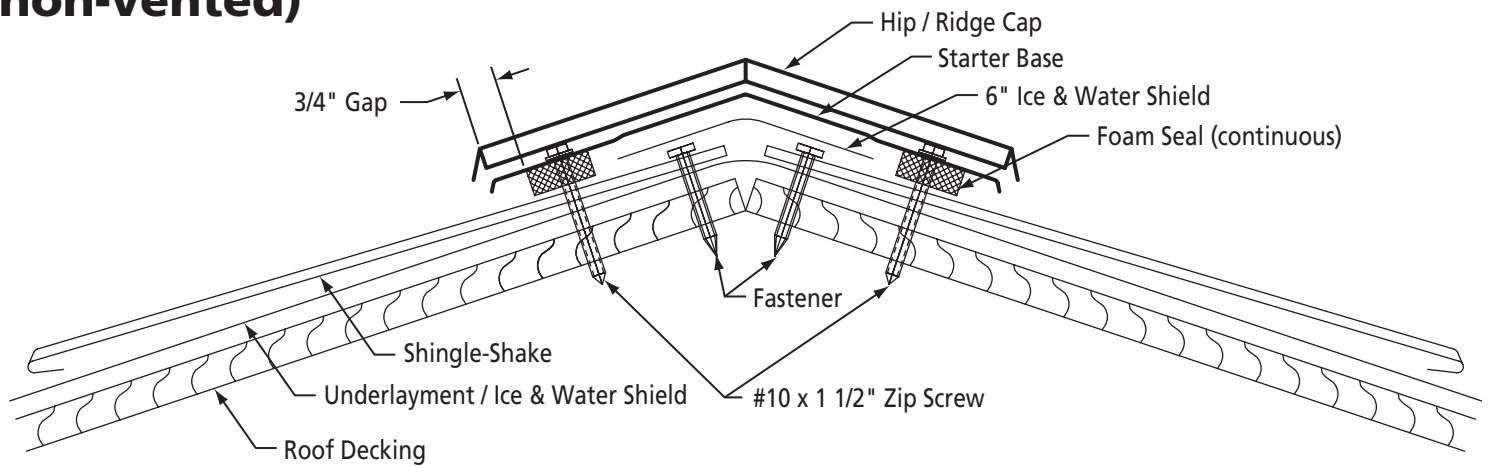

Cut shingle-shakes to the proper length and install as close to the hip or ridgeline as possible. Cover cut edges with 6" of ice & water shield centered along the entire length of the hip or ridge edge. Bend starter base with 10' brake to the correct roof pitch. Apply foam seal along the entire length of starter

base, approximately 3/4" from both corner edges. Install starter base over the shingle-shakes and overlap subsequent pieces approximately 4" using sealant. The hip / ridge caps should be installed over starter base with #10 x 1 1/2" steel zip screws using 2 shingle clips per hip / ridge cap.

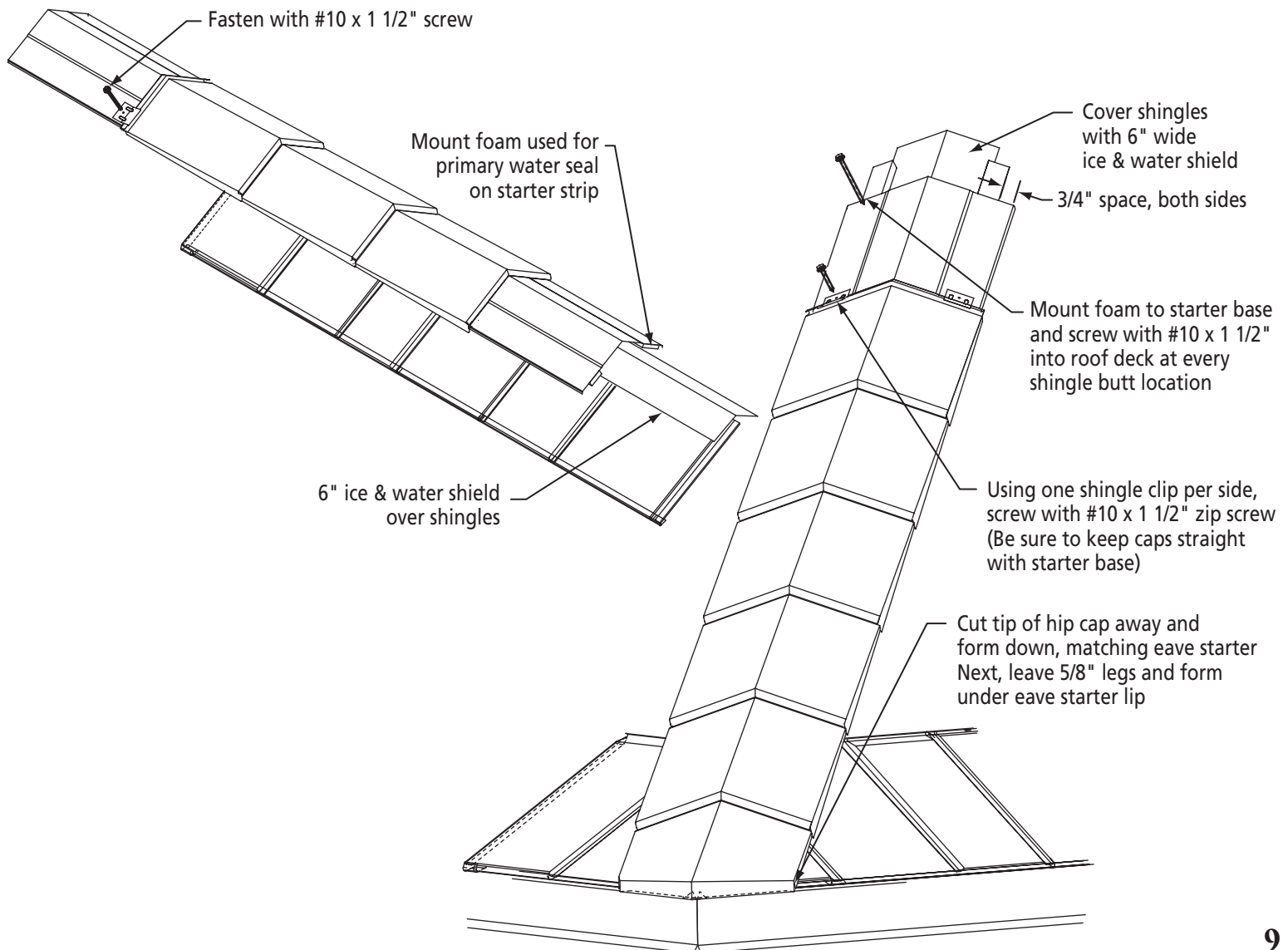

Hip / Ridge Assembly (Detail G)

(vented)

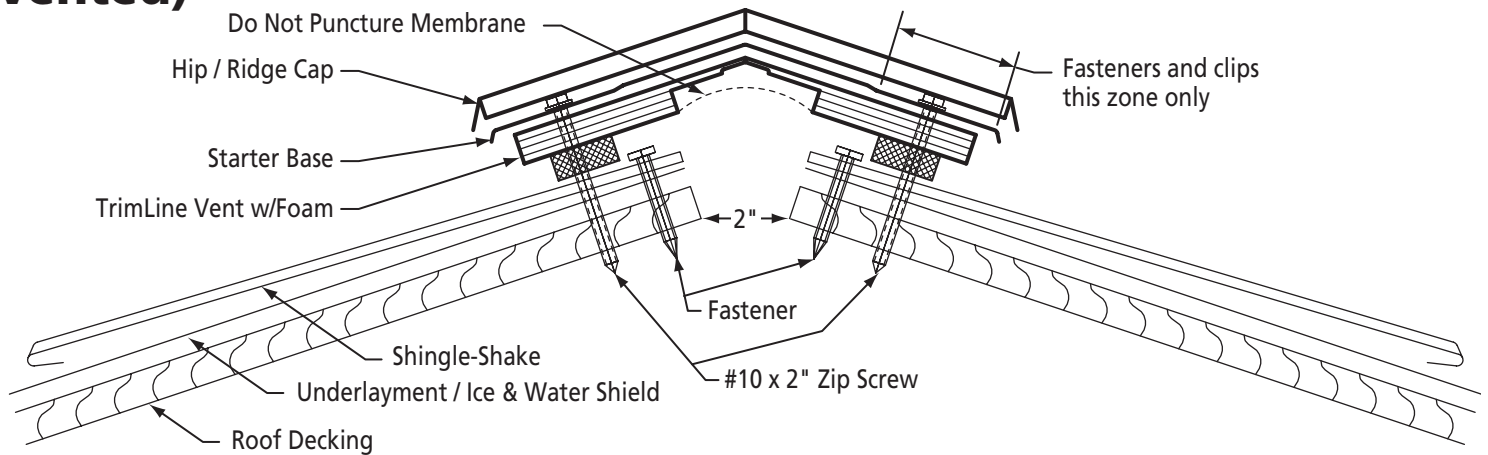

(1) When using the TrimLine vent system, first cut appropriately sized, 2" wide venting opening through the roof decking to no closer than 6" of the end walls. (See Ridge and Soffit Ventilation Requirements on p.11). When venting hips for more air flow, go down from the peak no more than 1/3 the maximum distance from the top. Going down the ridge too far effects air flow to the peak.

(2) Lay TrimLine vent (with foam) the full length of ridge, matching the pitch angle of the roof and keep straight. Tack and use sealant when necessary.

(3) Bend starter base to correct roof pitch over lapping 4" on splices. Use #10 x 2" steel zip screw spaced 12" apart to keep the vent system as flat as possible.

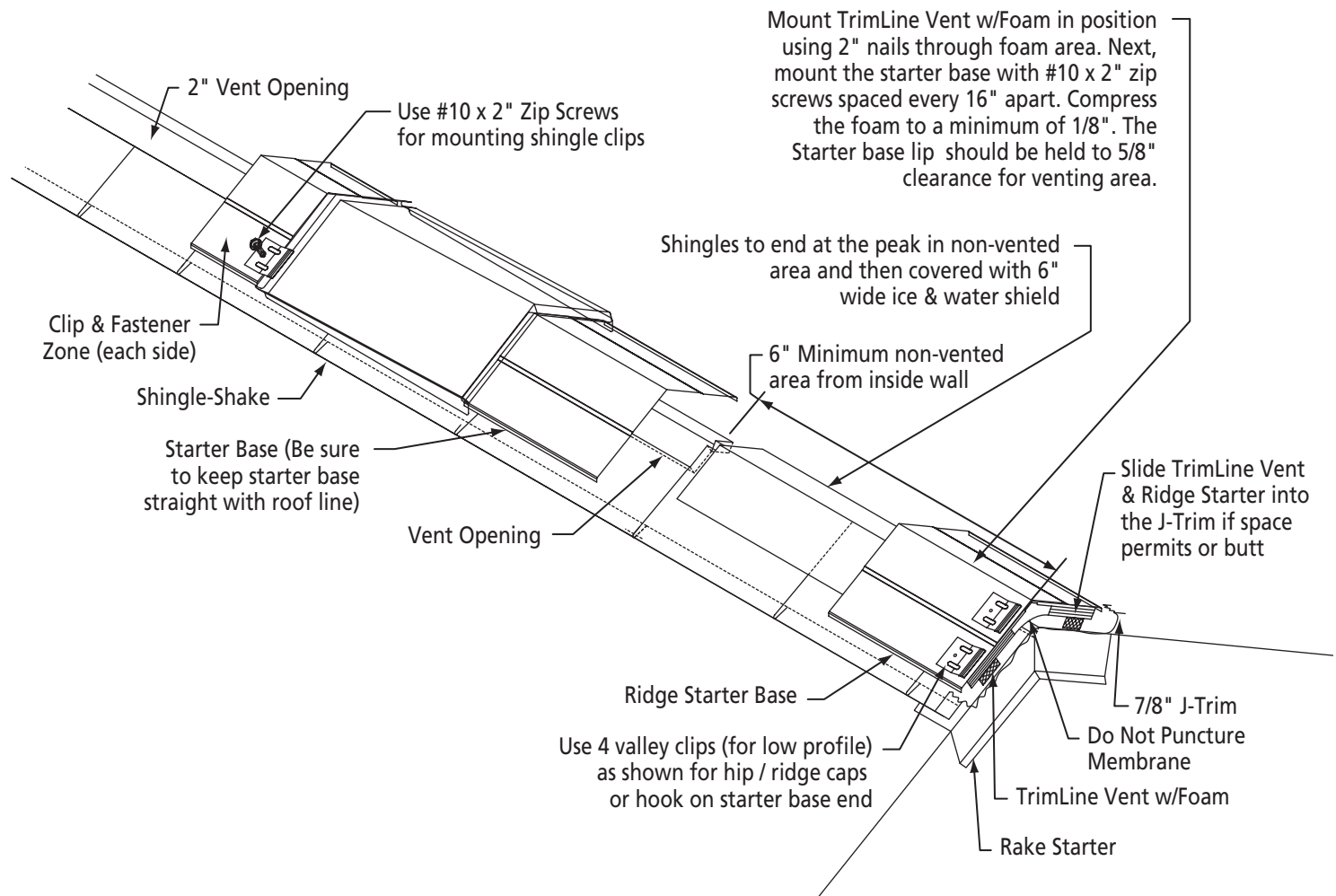

Ridge & Soffit Ventilation Requirements

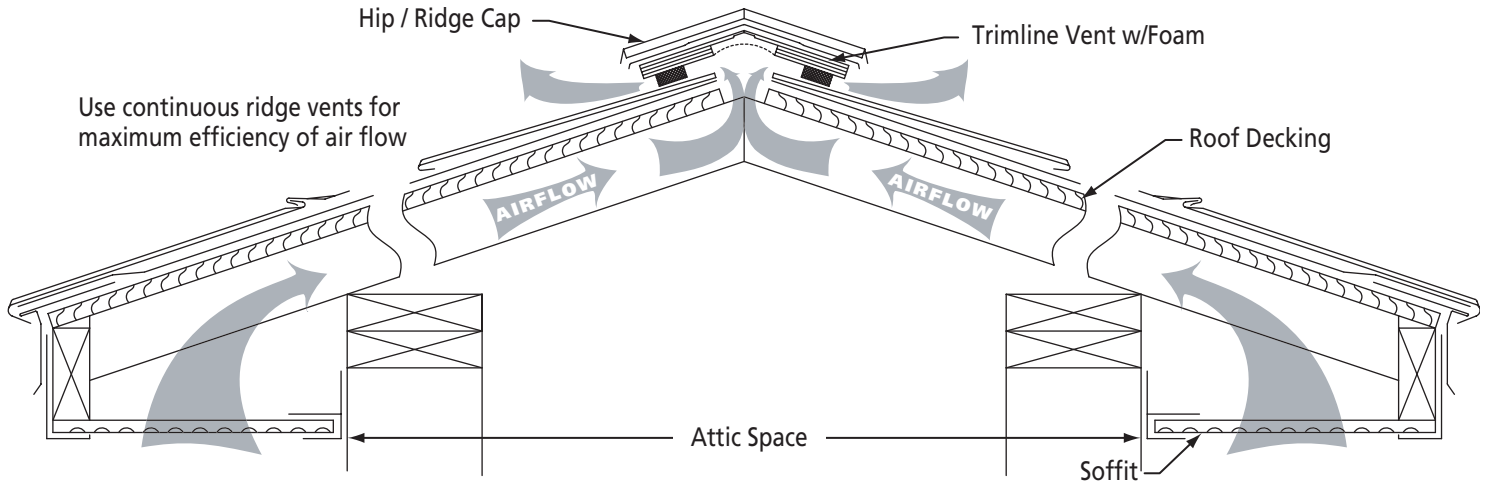

Calculations are based on equal ventilation at the ridge and at the eaves. This requires a 1:300 ratio (1 square foot of ventilation to every 300 square feet of attic space). (Check the local building codebook for exact requirements.) This

calculation is for 50% at the ridge and 50% at the soffit. Note: The soffit and ridge vent are to be at least equal to each other. The eaves are recommended to have an adder of 10% to 25%, this increases airflow pressure to the peak.

Calculations: using 5/8" thick Trimline Vent with 13 square inches / lineal foot of free air per foot.

1. Calculate attic floor space
30 feet wide x 40 feet long = 1200 square feet
2. Using 1:300 ratio net free airflow. (Total ridge and eave air flow)
1200 square feet / 300 square feet = 4 square feet
3. Calculation for the ridge or soffits (50% min. for each)
4 square feet / 2 = 2 square feet min.
4. Convert 1 square foot to square inches for one side
144 square inches x 2 square feet (Total for ridge or soffit) = 288 square inches per side
5. Trimline Vent Plus 5/8" thick (13 square inches net free air per foot) used for ridge venting and hip venting
288 square inches / 13 = 22.15 feet of ridge vent

Attic Sq. Ft.	Sq. Inches at Ridge	Min. Ft. of Vent	Sq. Inches Soffit Vent	Attic Sq. Ft.	Sq. Inches at Ridge	Min. Ft. of Vent	Sq. Inches Soffit Vent
1000	240	18	240	2100	504	39	504
1100	264	20	264	2200	528	41	528
1200	288	22	288	2300	552	42	552
1300	312	24	312	2400	576	44	576
1400	336	26	336	2500	600	46	600
1500	360	28	360	2600	624	48	624
1600	384	30	384	2700	648	50	648
1700	408	31	408	2800	672	52	672
1800	432	33	432	2900	696	54	696
1900	456	35	456	3000	720	56	720
2000	480	37	480				

Roof Vent Flashing

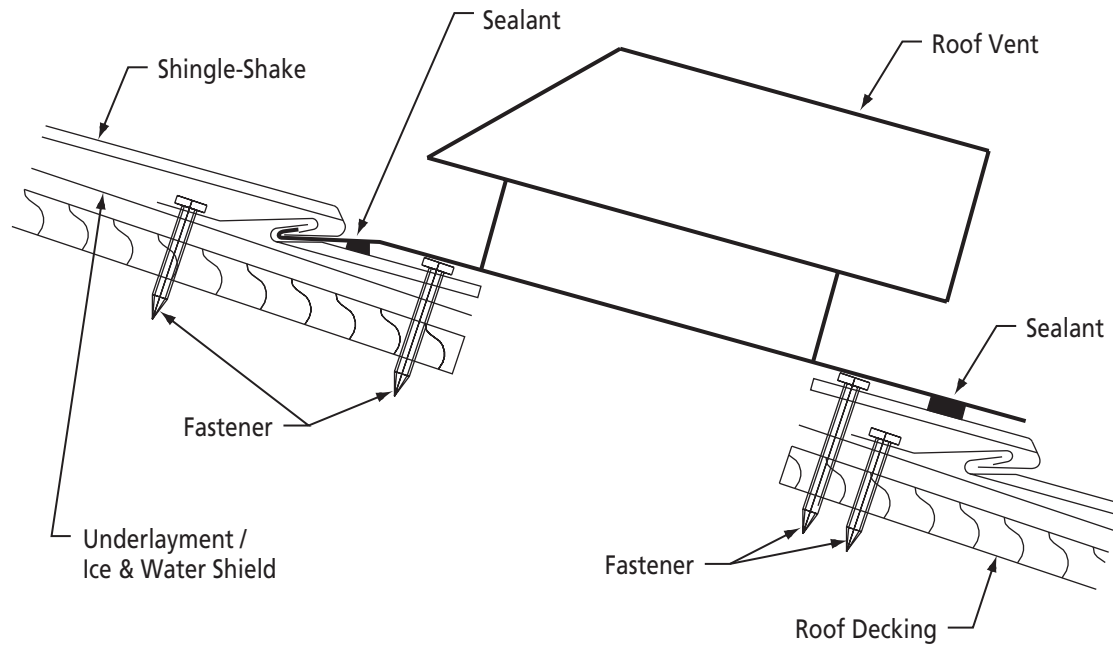

We recommend replacing all roof vents with the Trimline venting system (see page 10). Do not mix TrimLine vents with other roof or gable vents.

If individual roof vents are used to ventilate attic space, care should be taken in selecting an adequate number of properly

sized roof vents. The vents should have metal flashing attached and all manufacturer's installation recommendations should be followed. The metal flashings on the vents should be reworked (as shown above) to assure a watertight installation. Use painted zip screws to install, along with sealant under flashing and on all sides of vent.

Pipe Vent Flashing

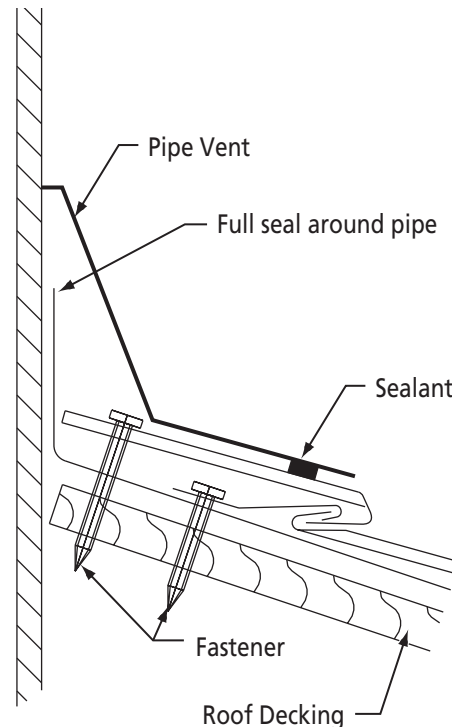
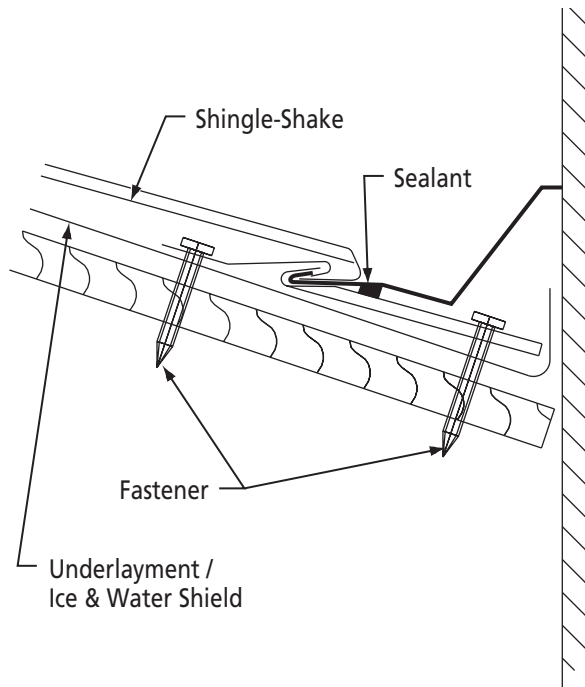

Select properly sized vent pipe (a tight fit is important) with metal or rubber boot flashing. Follow manufacturer's installation guidelines and use adequate sealant to assure

water tightness. Use painted zip screws to install, along with sealant under flashing and on all sides of vent.

Roof Jack

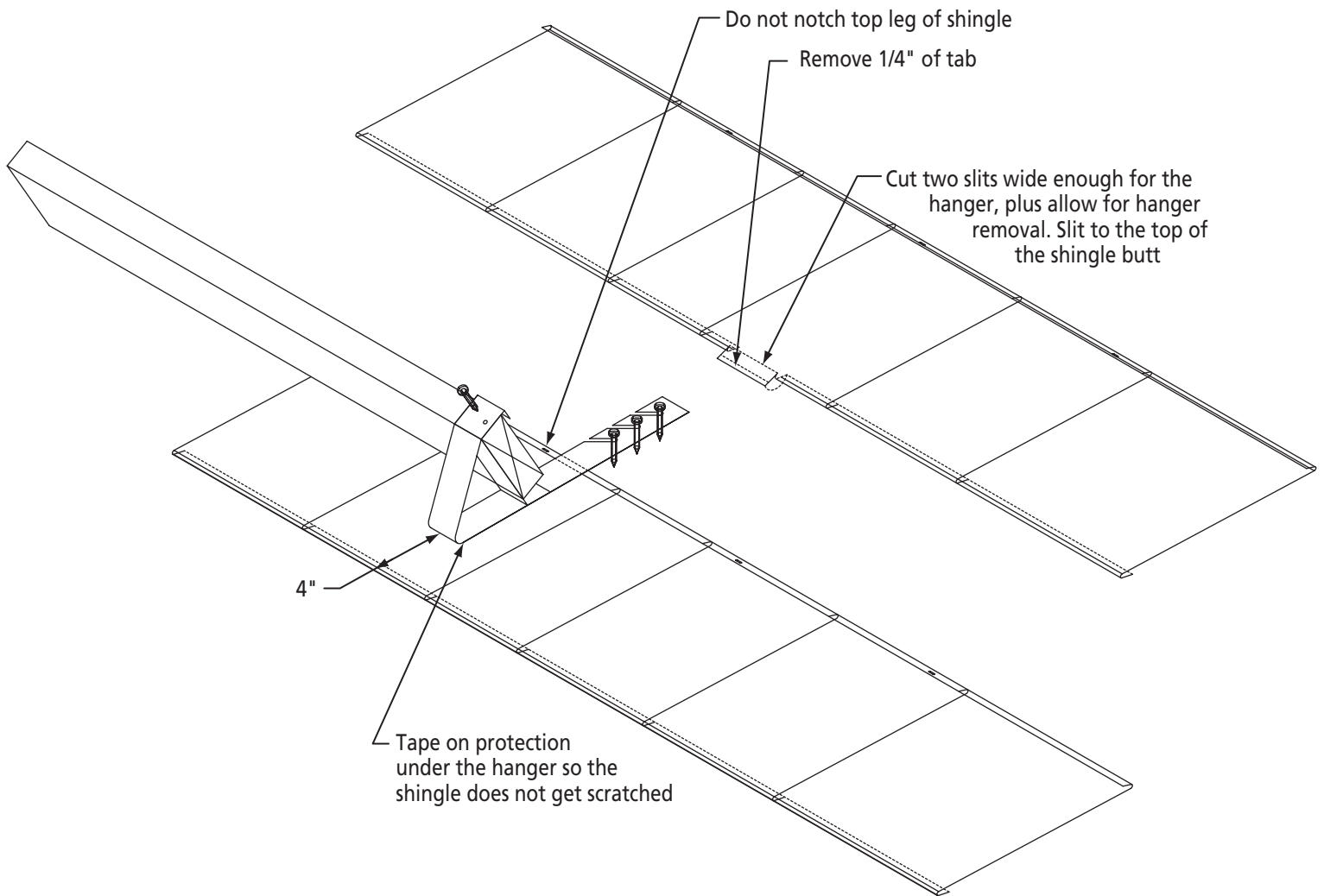

IMPORTANT

See hanger instructions from the manufacturer for proper use and mounting instructions required.

These instructions show modification of the shingle

1. Mount hanger over top of shingle per diagram.
2. Mount top shingle with clips.
3. Remove hanger when done installing shingles.
4. Put a thin protector plate under butt of shingle. Raise butt with a claw hammer on each side of tab when forming tab back in by hand. Do the final tuck with a narrow non-marring tool.

Shed Roof (vented)

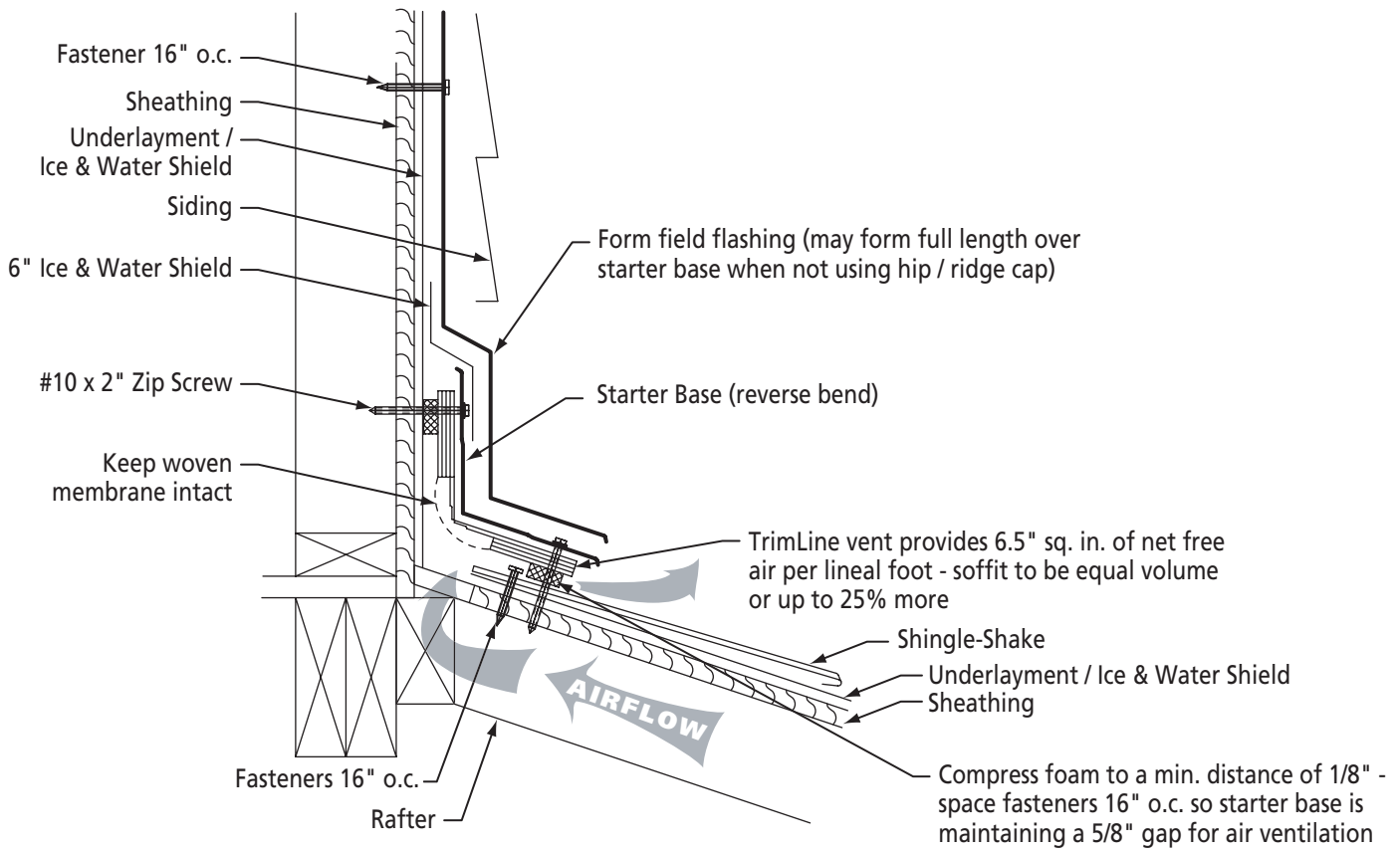

The vented shed roof is the same procedure of mounting as the standard ridge vent system except the Trimline vent is

reversed formed. (See p.10) Field-form a side wall flashing to cover the starter base.

Side Wall Installation (Detail G)

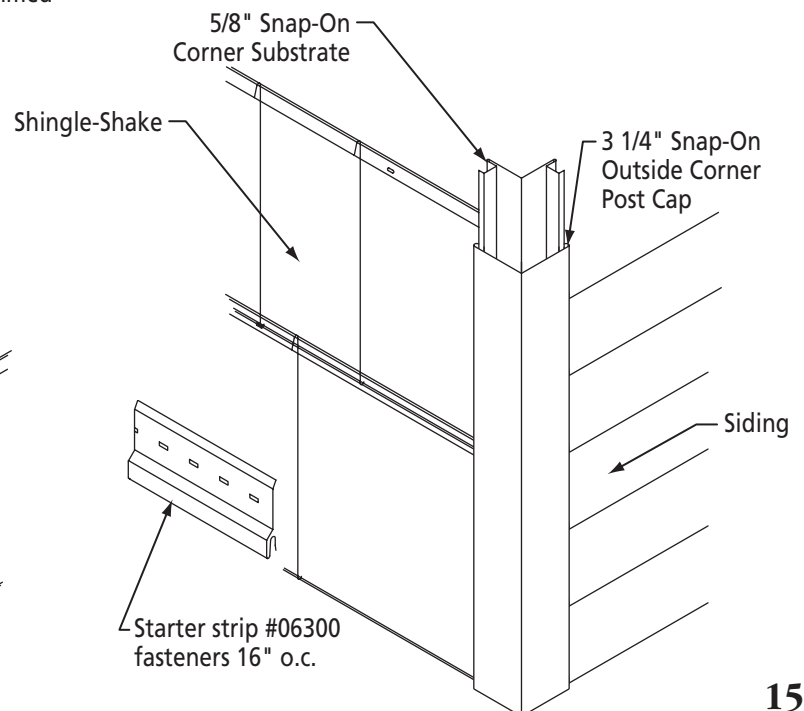
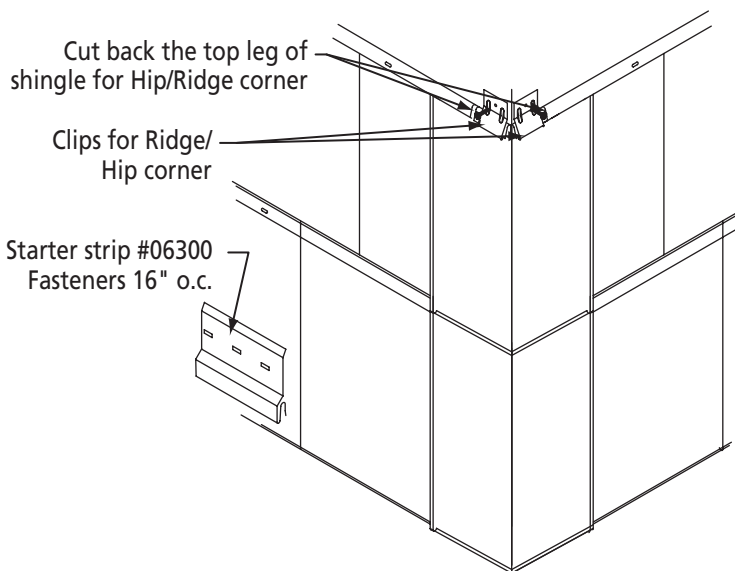
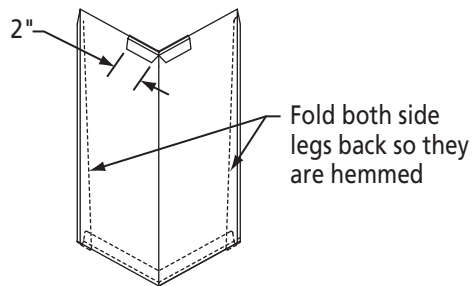
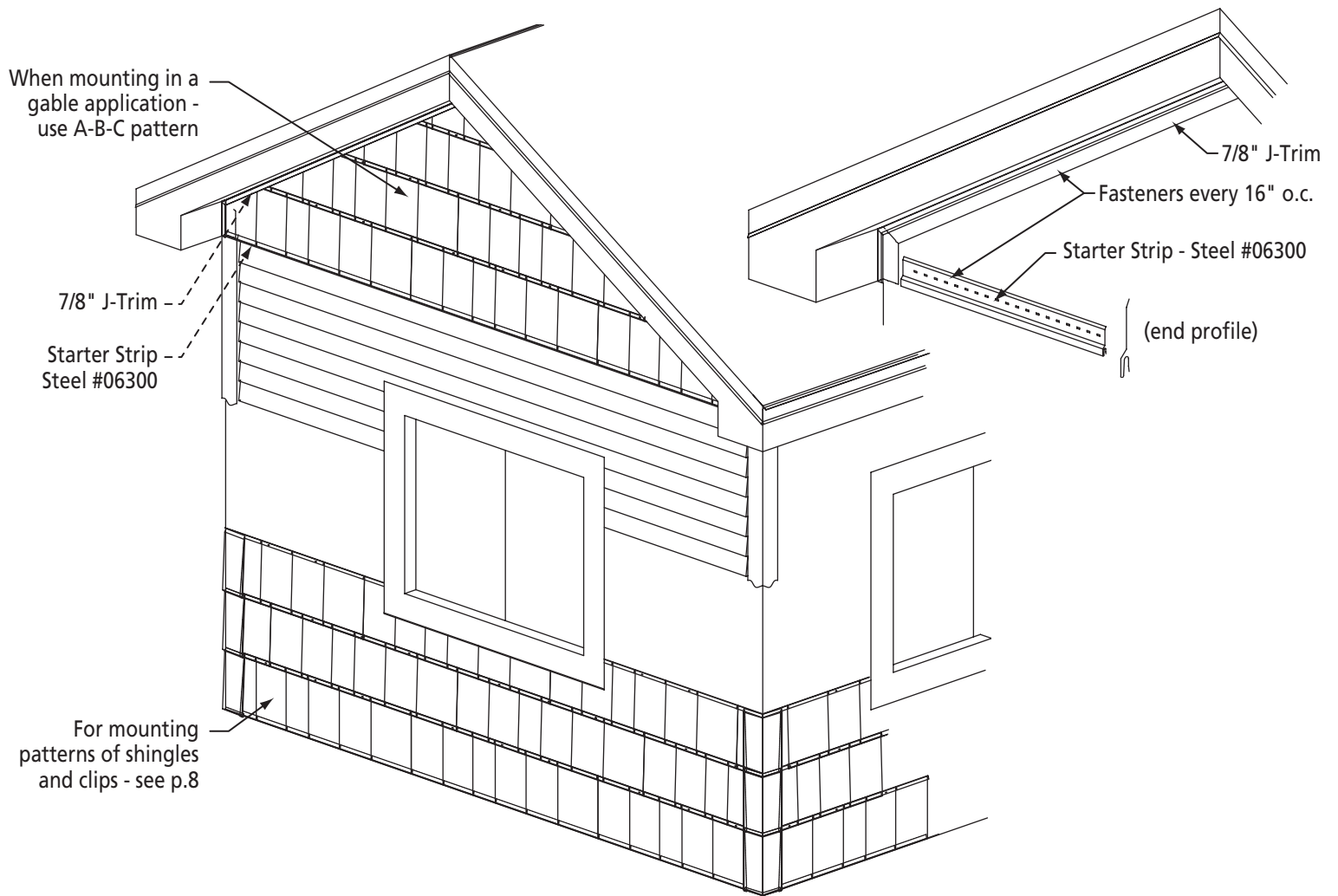

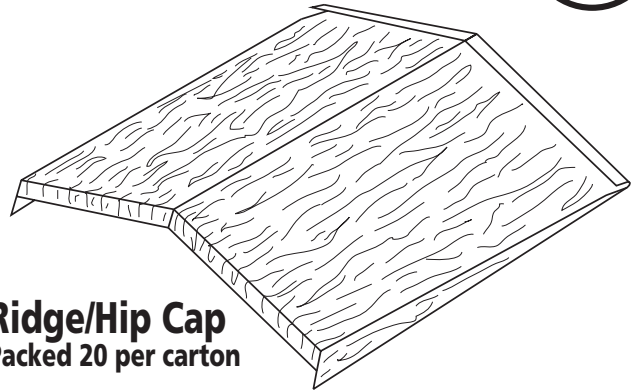
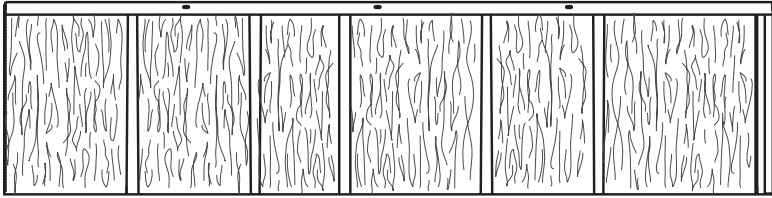

Shingle-Shake

12" x 50" 12 pcs per carton
50 sq.ft. Coverage

Ridge/Hip Cap
Packed 20 per carton

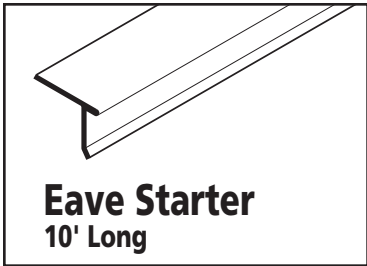

Eave Starter
10' Long

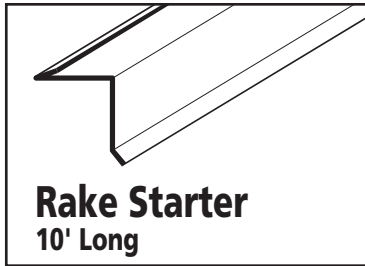

Rake Starter
10' Long

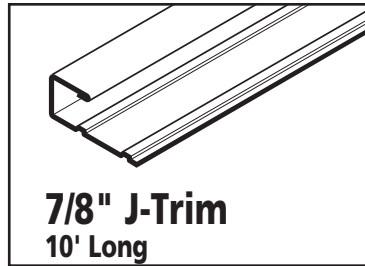

7/8" J-Trim
10' Long

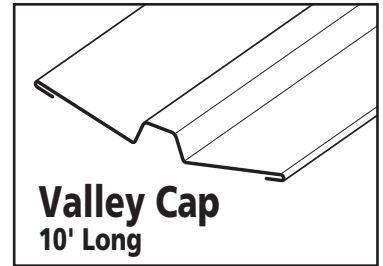

Valley Cap
10' Long

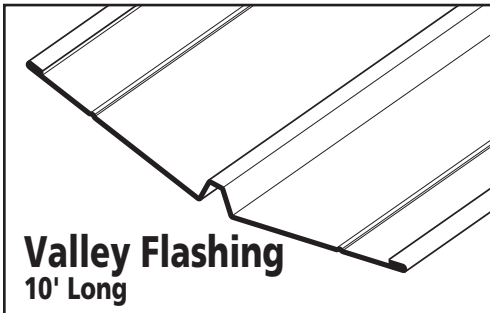

Valley Flashing
10' Long

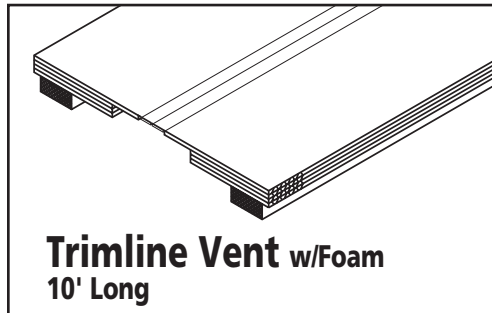

Trimline Vent w/Foam
10' Long

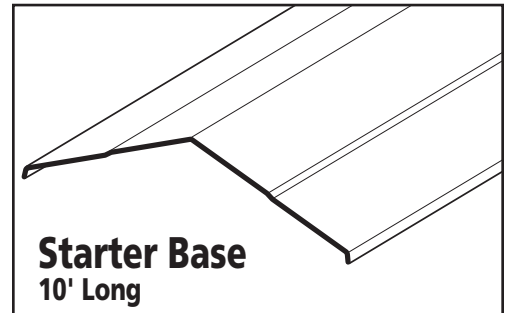

Starter Base
10' Long



Touch-Up Paint
1/2 oz. bottle



Foam Seal
30' Long



Trim Coil
15" x 50'

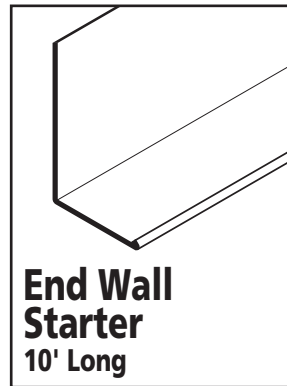

End Wall Starter
10' Long

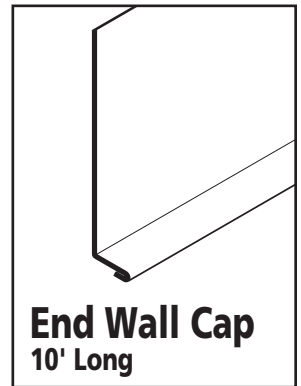

End Wall Cap
10' Long

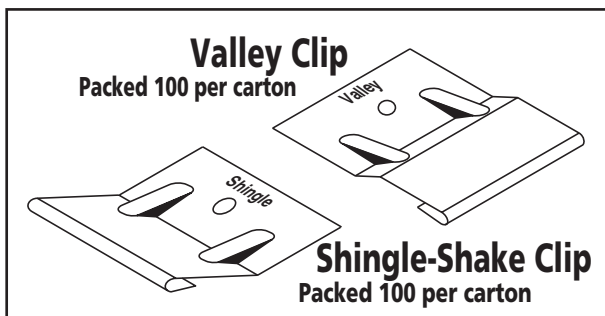

Valley Clip
Packed 100 per carton

Shingle-Shake Clip
Packed 100 per carton

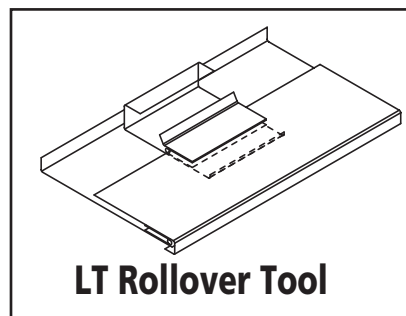

LT Rollover Tool